



"EXCELLENT ROADBUILDING FOR EXCELLENT JOB"

**SDC INTERNATIONAL CO., LTD.**

**PR950 COLD RECYCLER**



 **TEREX®**  
**PR950 COLD RECYCLER**

Features:

- High Production — 950 hp — 15 in (381 mm) Plunge Cut
- Excellent Maneuverability — 3 or 4 Track Design



**PR950 COLD RECYCLER**

**Cutter**

Standard width	7 ft 2 in (2,184 mm)
Optional width (3 options)	8 ft 7 in (2,616 mm) 11 ft 3 in (3,429 mm) 12 ft 6 in (3,810 mm)
Depth of cut	15 in (381 mm)
Drive	Mechanical, v-belts
Clutch	Hydraulic actuated

**Engine**

Manufacturer	CAT <sup>®</sup>
Model	C27
Horsepower	Horsepower 950 hp (708 Kw) at 2100 rpm
Torque	3,202 lb-ft (4,341 N.m) at 1,400 rpm
Number of cylinders	12
Displacement	1,649.47 in (27.03 L) 3
Fuel consumption half load	21.8 gal/hour (82.5 L/hr)
Fuel consumption full load	45.7 gal/hour (173 L/hr)
Electrical system	24 VDC

**Machine Drive**

Tracks	4-tracks/3-tracks
Drive system	Hydrostatic
Work speed	0 – 74 fpm / 0 – 105 fpm (0 – 23 mpm / 0 – 32 mpm)
Work speed	0 – 119 fpm / 0 – 133 fpm (0 – 36 mpm / 0 – 41 mpm)
Work speed	0 – 170 fpm / 0 – 175 fpm (0 – 51 mpm / 0 – 53 mpm)
Travel speed	3.2 mph (5.15 kph)
Service brakes	Hydrostatic/dynamic
Parking brakes (all tracks)	Spring applied hydraulic release



## PR950 COLD RECYCLER



### Steering

Type	Hydraulic power/proportional
Modes	4 steering modes
Turning radius 4-track	8 ft (2,438 mm)
Turning radius 3-track	8 ft (2,438 mm)

### Conveyors

Lower conveyor	42 in (1,067 mm)
Upper conveyor	42 in (1,067 mm)
Swing	60°
Drive	Hydrostatic with reverse

### Tank Capacities

Fuel	410 gal (1,552 L)
Hydraulic oil	65 gal (246 L)
Water	1,220 gal (4,618 L)

### Dimensions & Weights

Overall length, tractor	33 ft 3 in (10,135 mm)
Overall length, with conveyor	55 ft 7 in (16,942 mm)
Overall width	9 ft 2 <sup>3</sup> / <sub>4</sub> in (2,813 mm)
Overall height	11 ft 6 in (3,505 mm)
Shipping weight 4-track	84,000 lbs (38,102 kg)
Operational weight 4-track	98,620 lbs (43,733 kg)
Shipping weight 3-track	76,500 lbs (34,700 kg)
Operational weight 3-track	90,620 lbs (41,105 kg)

### Features

- Independent angle-of-attack adjustment for extensions
- Quick-attach extensions for wider paving capability
- Screed assist system for greater screed control
- Electric-over-hydraulic for simple accurate operation
- Hardened alloy screed plates offer longer service life

### Stretch Screed Specifications

Model	maximum Paving Width	Weight	Screed Plate Width	Vibrator Speed
Stretch 16	18 ft	5700 lbs	18 in x 8 ft	2600 vpm
	5.5 m	2591 kg	457 mm x 2.4 m	
Stretch20	26 ft	7000 lbs	19 in x 10 ft	2600 vpm
	7.9 m	3182 kg	483 mm x 3.0 m	

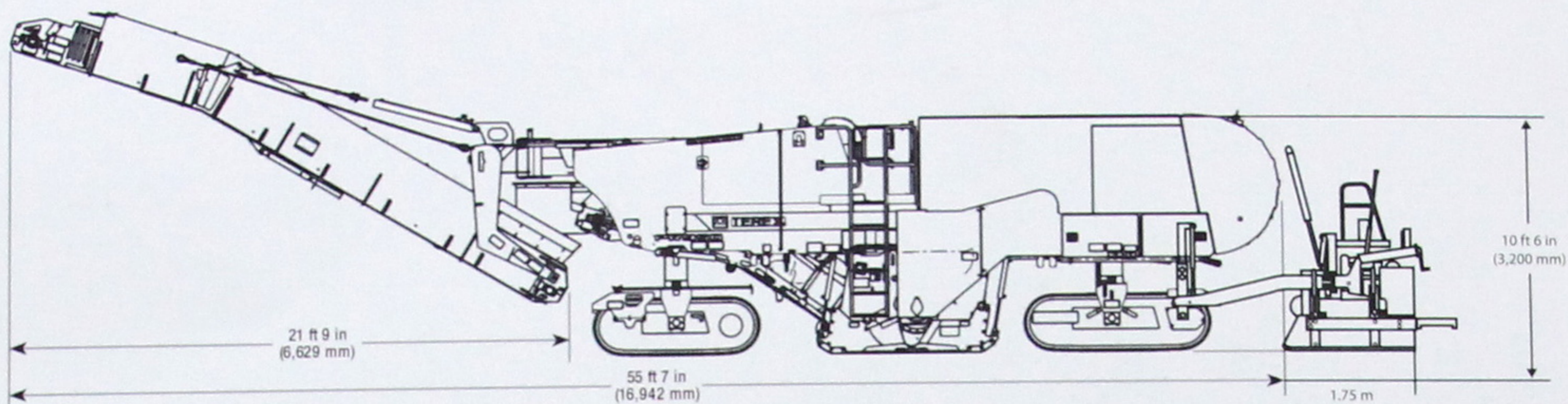

## PR950 COLD RECYCLER



**SDC INTERNATIONAL CO., LTD.**  
 "EXCELLENT ROADBUILDING FOR EXCELLENT JOB"

96/52-53 Moo 9, Rama2 Rd., Bangmo  
 Jomthong, Bangkok 10150 (Thailand)  
 Tel: (662) 896-0464-5, (662) 8960797-8 Fax: 02-896-06  
 e-mail: [info@sdcenter.co](mailto:info@sdcenter.co)  
 website [www.sdcenter.co](http://www.sdcenter.co)